

IF IN DOUBT ASK

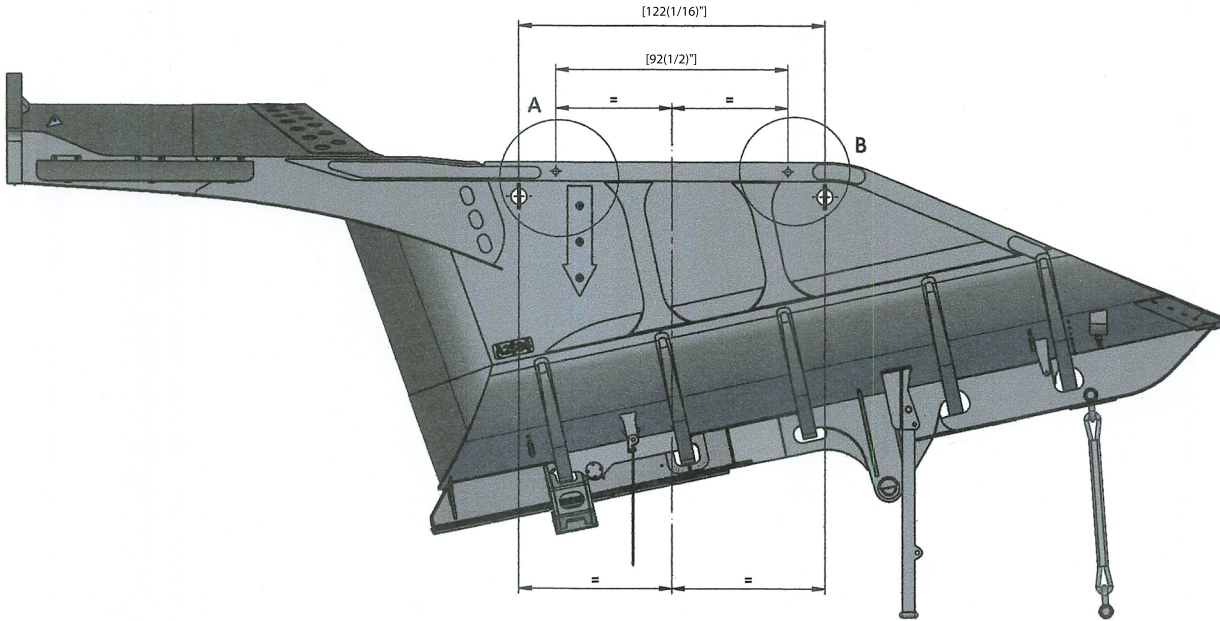

NOTES:
1 - REFER DOCUMENT SCH-QA-PRO-009 FOR WELD GUIDELINES

Q1	APPROVED FOR PRODUCTION	-	A Boswell	16/10/2025
REV	DESCRIPTION	REVISED	APPROVED	DATE

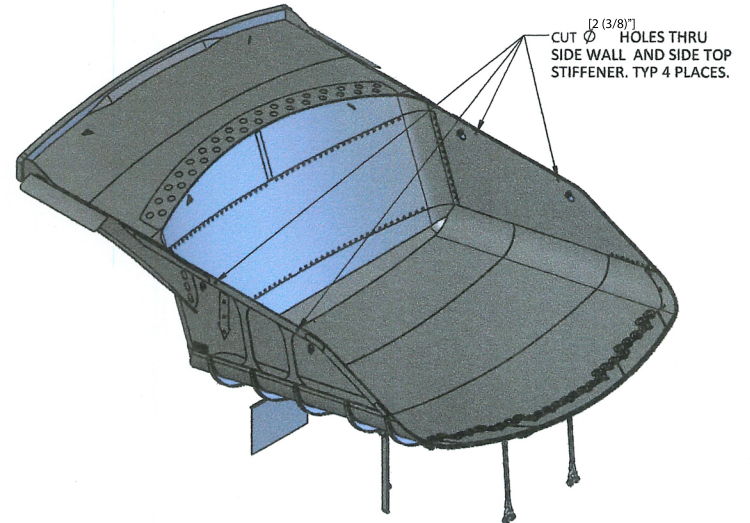
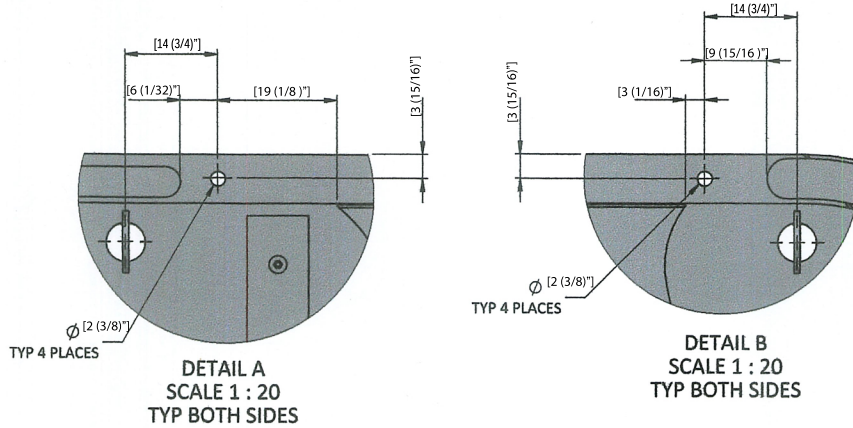

PROPRIETARY AND CONFIDENTIAL
BY SCHLAP
THE INFORMATION CONTAINED IN THIS DRAWING IS THE SOLE PROPERTY OF SCHLAP.
ANY REPRODUCTION IN PART OR AS A WHOLE WITHOUT THE WRITTEN PERMISSION FROM SCHLAP IS PROHIBITED

TOLERANCES		
MACHINING: ± 0.25mm		
FABRICATION: ± 2.00mm		
BENDING: ± 0.50"		
DIMENSIONS IN mm's UNOS		
NAME	DATE	
APPVD: A. Boswell	16/10/2025	
CHKD: A. Boswell	16/10/2025	
DRAWN: J. Berry	16/10/2025	

FINISH:	NATURAL
PROJECT:	TRX-MT4400-RIO-BOR-146-25-12-2023
TITLE:	MODIFICATION ASSEMBLY

SCALE	WEIGHT
A3	31590 kg
REV. 01	SHEET 1 OF 1
DRAWING No. DT1182-MI04655-PR	